

CM-P1 / CM-EP1
Conventional Fire Alarm Control Panel

Manual Book

2020-09-11 REV-1

7114-001-V

CONTENTS

I. General Introduction	3
II. Features	3
1. Two-stage delay function	3
2. Standby battery protection	3
3. Protection against lightning surge	3
4. Abnormal voltage inspection	3
5. Modular design	4
6. Exterior design	4
7. Other function	4
III. FACP Dimensions, LED Indicator and Switch Function	5
1. System Indicator	6
2. Power Indicator	7
3. Fire Indicator	7
4. Audio Switch (Panel Mute)	8
5. Linkage Stop (Alarm Relay Disable)	8
6. Function Selection (Alarm Activation Disable)	9
7. Test Switch	9
8. Battery Test	9
9. Reset (System Reset)	9
IV. Specification	10

CONTENTS

V. System Status	11
1. System Normally in AC Power	11
2. System Normally in Battery Power	11
3. Alarm Indicator	11
4. AC Power Fault	12
5. Battery Power Fault	12
VI. Wiring Diagram of Fire Alarm Control Panel	13
1. Main Control Board	13
2. Control Panel Wiring to Alarm Device	16
3. Control Panel Wiring to Annunciator	19
4. Control Panel Wiring to Broadcast System	20
5. Control Panel Wiring to Smoke Evacuation System	22
6. Control Panel Wiring to Sprinkling and Foam System	23

I. General Introduction

All base boards use a modular design. Performance of the circuit is stable. And the appearance is simple and elegance. With two phase signal hold function to reduce false alarm, operator can know the situation instantly and maintenance is easy.

II. Features

1. Two-stage delay function

At the first stage, when detector sends the signal for the first time, the control panel will automatically reset the signal and enter the second stage for standby after 8 seconds.

At the second stage, if there is another signal send by the detectors within 9-40 seconds, the control panel will triggered the fire alarm, else reset the alarm signal. This will prevent the control panel from sending false alarms.

2. Standby battery protection

During power-cut, when the standby battery is under DC 18V, it will automatically stop discharging to extend battery life.

3. Protection against lightning surge

Power supply module with protection against lightning surge to avoid device damage caused by high voltage or power surge.

4. Abnormal voltage inspection

With abnormal voltage display function, the system can indicate high and low voltage.

5. Modular design

The system has modular design with inputs / outputs independent terminal module. If there is a problem on site, users do not have to remove external wires and can easily replace defective boards improving the efficiency of maintenance and inspection.

6. Exterior design

Equipped with zone display panel board, the panel (made of flame retardant plastic) adopts a streamline design for clear indication of zone's name, floor, building, properties, etc.

7. Other function

Control panel can be integrated with the TYY Voice Evacuation System (Broadcast system) and the Emergency Telephone System in one cabinet for more appealing look and less space consuming.

III. FACP Dimensions, LED Indicator and Switch Function

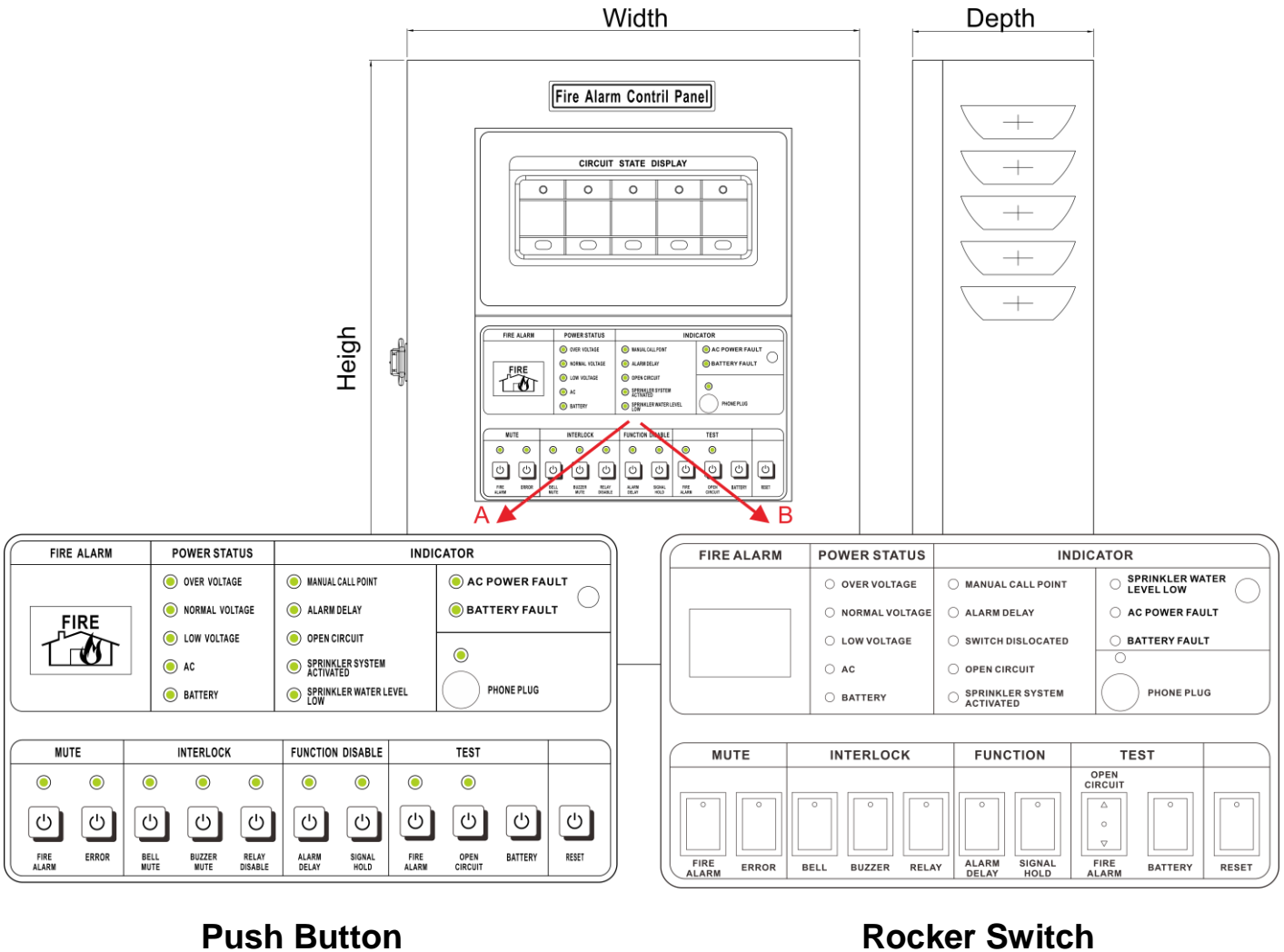

Number of Zone (Dimensions - Steel)						
Zone	H*W*D	Zone	H*W*D	Zone	H*W*D	
5L~10L	400*300*120	65L~70L	840*480*200	135L~150L	1800*580*260/360	
15L	495*300*120	75L~80L	930*480*200	155L~170L	2000*580*260/360	
20L	580*300*120	85L~90L	1020*580*200	2 In	135-260L	1600*1160*260/360
25L~30L	520*480*180	95L~100L	1110*580*200		265-300L	1800*1160*260/360
35L~40L	580*480*180	105L~110L	1195*580*200		305-340L	2000*1160*260/360
45L~50L	700*480*180	115L~120L	1350*580*200	3in : 345~450L		1800*1740*260/360
55L~60L	760*480*180	125L~130L	1600*580*260/360	4in : 455~600L		1800*2320*260/360
Dimensions - ABS						
5L-10L	400*300*126	15L-20L	370*480*90			

1. Status Indicator

※ **Manual Call Point Signal Lamp:**

The LED red light with “Fire” lamp flashing and zone LED red light indicating the manual call point of that area pressed by someone.

※ **Accumulation Indication Lamp (Alarm Delay):**

The LED red light indicating the circuit in delay function.

※ **Switch Is Not Positioned (Switch Attention):**

The LED yellow light indicating somewhat switch function not position.

※ **Disconnection Indication Lamp (Zone Open Circuit):**

The LED yellow light and control panel’s buzzer send out beep sound that is indicating external of zone circuit device broken or zone circuit disconnected, or terminal of zone not yet wiring E.O.L 10KΩ resistor.

※ **Fire Fighting Activated Lamp (Active Fire Protection):**

The LED yellow flashing and control panel’s buzzer send out beep sound that is indicating fire protection pump is activated (Pump 1 contact).

※ **Insufficient Fire Fighting Water Lamp (Insufficient Water for Sprinkler):**

The LED yellow flashing and control panel’s buzzer send out beep sound that is indicating insufficient water in fire protection pump tank (Pump 2 contact).

※ **AC Power Fault:**

The LED yellow flashing with buzzer beep sound that is indicating the AC Power is OFF.

※ **Battery Fault:**

The LED yellow flashing and with buzzer beep sound that is indicating the Battery Power is OFF.

※ **Telephone Call Lamp (Incoming Call):**

The LED red light and control panel's buzzer send out long beep sound that is indicating have calling from manual call point or annunciator area, let plug in phone set for communication with each other.

2. Power Indicator

※ **Over Voltage:**

The LED red light that is indicating the voltage of power supply over than standard voltage. (Standard voltage around DC 18V to 32V).

※ **Normal Voltage:**

The LED green light that is indicating the power supply voltage normally.

※ **Under Voltage:**

The LED yellow light that is indicating the power supply voltage under than standard voltage.

(Note: directly read the volume in voltmeter with voltmeter indicator type).

※ **AC Lamp:**

The LED green light that is indicating AC power supply in normal condition.

※ **Reserve Power Lamp (Battery):**

When AC power supply is disconnected, the LED yellow light that is indicating standby power already supply for system.

3. Fire Indicator

- ※ **Fire:** The LED red flashing and zone circuit LED red light and control panel's buzzer send out long beep sound, fire alarm bell ringing, lamp indicator red flashing, etc. That is indicating the control panel is activated by receipt fire signal send by detector or manual call point.

4. Audio Switch (Panel Mute)

※ **Main Sounder (Fire Alarm):**

When the control panel is activated, buzzer of control panel send out long beep sound, press this switch to mute the fire alarm sound of buzzer.

※ **Warn Sounder (Trouble Alarm):**

The buzzer of control panel send out beep sound by receipt a zone device circuit is disconnected or broken, fire protection system is activated or insufficient water for sprinkler and foam system, press this switch to mute the warning sound.

5. Linkage Stop (Alarm Relay Disable)

※ **Zone Sounder (Bell):**

The fire alarm bell will ring when the control panel is activated. Press this switch to disable the sound of fire alarm bell.

※ **Buzzer (Gate):**

The fire alarm buzzer is activated / gate is open after the control panel is activated. Press this switch to disable buzzer's sound / gate is close.

※ **Transfer Report (Broadcast):**

When control panel is activated, fire signal relay to activated broadcast system. Press this switch to disable the fire signal from control panel relay to activated broadcast system.

6. Function Selection (Alarm Activation Disable)

※ Accumulation (Delay):

The control panel is in delay function after receipt signal send by zone circuit's device. Press this switch to disable delay function of control panel; the control panel is activated directly after receipt fire signal from zone circuit.

※ Auto-Reserved (Signal Hold):

“Signal Hold” mode and “Signal Hold Disable” mode are available for operators to set if they want the control panel to automatically reset the fire alarm signals after the fire extinction or not.

7. Test Switch

※ Motion Test (Fire Alarm):

Testing fire alarm function of control panel and system devices working normal or abnormal.

※ Disconnection Test (Open Circuit):

Testing open circuit indicator of control panel and system devices working normal or abnormal.

8. Battery Test

Testing the battery power voltage supply.

9. Reset (System Reset)

The switch allows you to reset all alarm notification, remove alarms signal, reset detectors, and return the system to a normal state.

IV. Specification

Item	Specification
Model	CM-P1 / CM-EP1
Category	Conventional Fire Alarm Control Panel
Type	Wall-mount / Floor-standing
Power Source	110V AC 50 / 60 Hz or 230V AC 50 / 60Hz
Standby Battery	24V DC
Charging Voltage	Below 26V DC 450mA, trickle charging
Circuit Voltage	24V DC operation voltage, under 10~11V DC 32mA
Rated Impedance	Under 50 Ω , Ground Resistance above 2M Ω
Detector Connection	No limitation for of Conventional Rate of Rise Heat / Fixed Temperature Heat Detectors; Up to 30 Photoelectric Smoke Detectors (DC 24V 40 μ A) per zone.
E.O.L Resistor	10k Ω
No. of Indicators	1.2 times of the number of zone (LED indicating lamp)
No. of Bell	1.2 times of the number of zone.
Color	Green / Red / Black
Buttons	Rocker Switch / Push-Button / Capacitive Touch Switch
Cabinet Material	Powder coating steel (optional Flame retardant ABS enclosure available up to 20L only)
Main Audio	Mono tone sounder (above 85dB for 1m distance)
Alarm Relay Contact	2 sets of No-Voltage NO contact, capacity AC 250V / 7A

V. System Status

1. System Normally in AC Power

- AC power LED on; Normal voltage LED on.
- The zone state is normal, zone LED off.
- Control panel switch in position, the switch corresponding LED off, and any switch function on the control panel should work normally.
- Function of each LED indicator of control panel and system devices should work normally.

2. System Normally in Battery Power

- AC power supply disconnect, AC power LED off.
- Zone voltage is normal, Normal Voltage LED on.
- The zone state is normal, zone LED off.
- Control panel switch are position, the switch corresponding LED off, Function of each switch on the control panel should work normally.
- Function of each LED indicator on the control panel and system device should work normally.

3. Alarm Indicator

- Fire Alarm:

The zone LED red light, control panel's buzzer send out beep sound continuously, the local bell sounder continuously, the "Fire" indicator LED flashing (intervals of 0.5 second), if any relay switch of panel not in position (switch LED red light) signal relay to other devices will be disable.

- Zone open circuit:

Zone LED flashing (intervals of 1 second), control panel's buzzer beep sound. Check the zone circuit and zone devices, capacitive EOL device to fix problem.

- Insufficient Water:

The LED yellow flashing, indicating insufficient of foam or water in fire protection pump tank. Control panel's buzzer send out beep sound, press "Trouble" switch to mute the beep sound.

When control panel's AC power supply is disconnecting, switching automatically to the battery power. The AC power LED off at this time, and other relay devices are as same as the previous state. After the protected areas in normal condition, users may press "System Reset" to reset all control panel.

4. AC Power Fault

- AC Power indicator supply LED off.
Check AC power supply and power switch in main board, check AC fuse.
- The fuse LED red meaning fuse fault. Check the Ampere of fuse before changing.

5. Battery Power Fault

- Check the DC power and battery switch in main board, check battery fuse.
- Battery is DC power, battery circuits has positive and negative pole. The positive pole is usually marked red (or "+") and the negative pole is usually marked black (or "-"). Check electrical polarity before installing to Main Control Board.
- If AC power disconnect, control panel will automatically switch to the standby battery power. When the battery voltage is below 9.8V, the Normal Voltage led is off, the control panel will automatically shutdown. Awaiting the AC power is normal, the battery is automatically charged. If the battery cannot be charged, it is a need to change the battery.
- Finally replace a new battery.

Note: Please disable the battery power if AC power disconnect, avoid battery fault or discharging for long time and out of electrical.

VI. Wiring Diagram of Fire Alarm Control Panel

1. Main Control Board

a. (YFP-T6-4E): 5L~ 80L

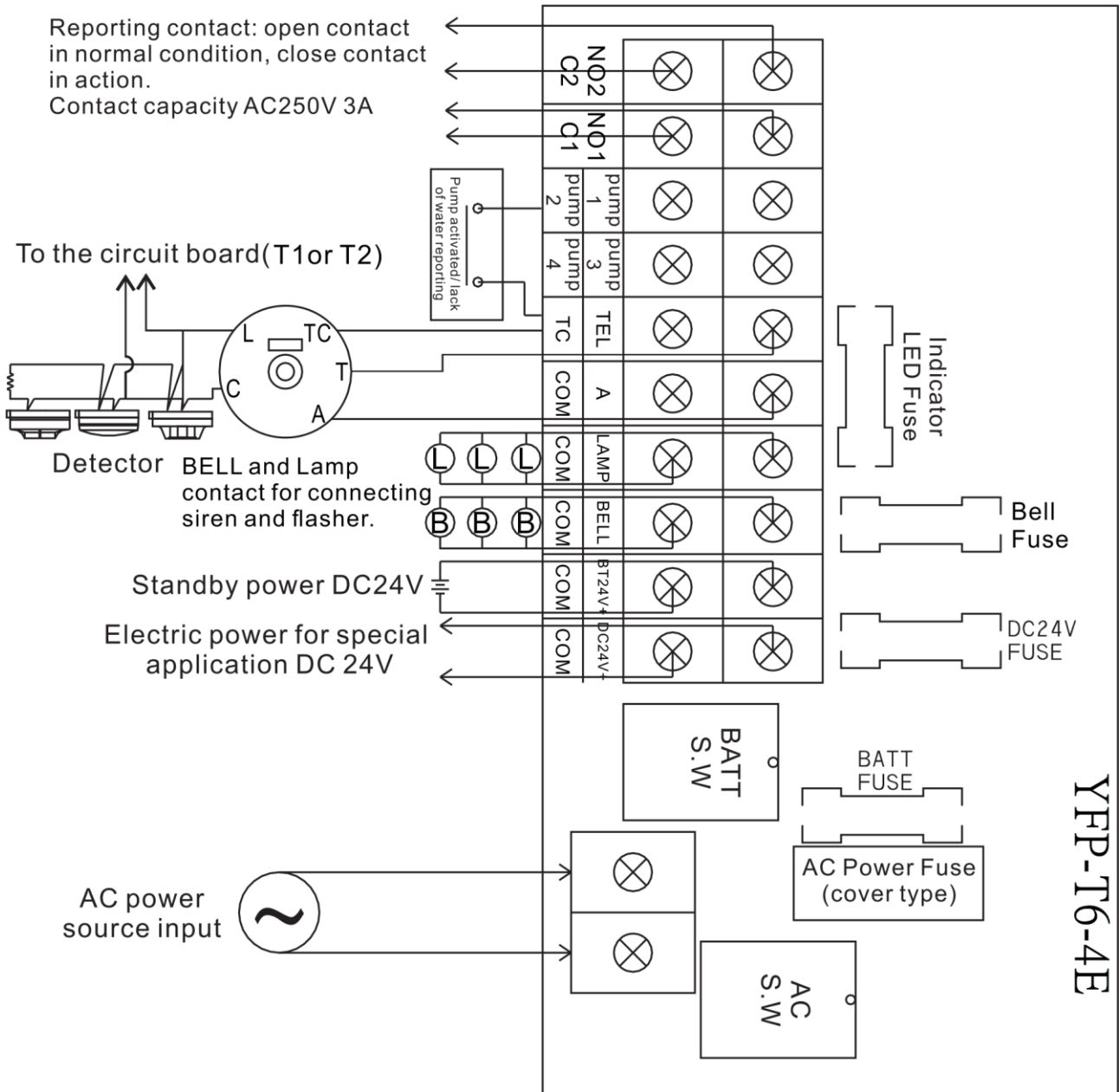

b. (YFP-T6-3E): above 80L

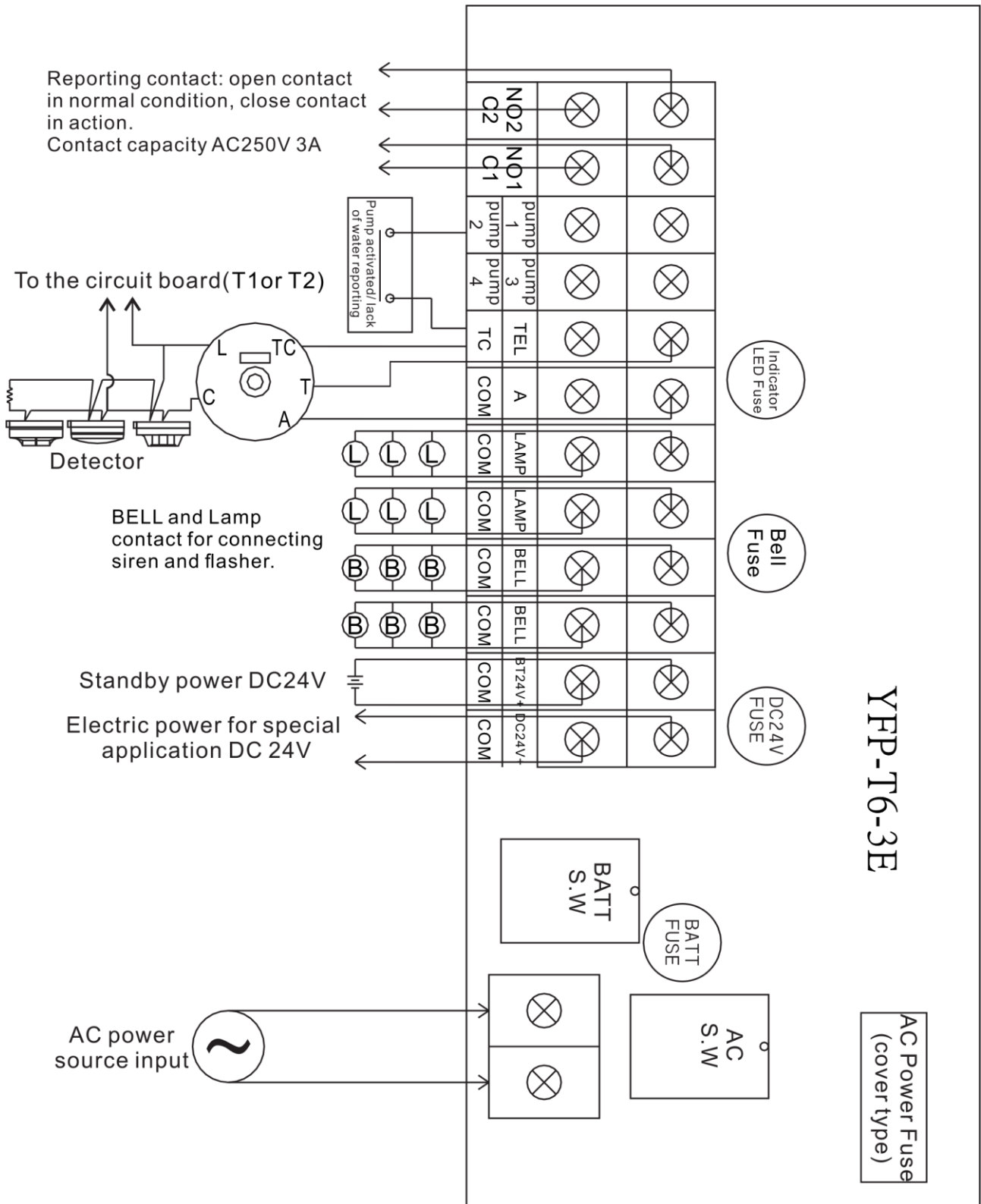

Notes for Installation Main Control Board:

- Battery is DC power, battery circuits has positive and negative pole. The positive pole is usually marked red (or “+”) and the negative pole is usually marked black (or “-“). Check electrical polarity before installing to Main Control Board.
- Disable the battery power if AC power disconnect, avoid battery fault or discharging for long time and out of electrical.
- The fuse LED red if fuse is fault. Check the Ampere of fuse before changing.
- Please check that all Pumps and Insufficient Water wiring to no voltage contact point.
- Device circuit’s insulation must be greater than 2MΩ.
- Estimate Electric Consumption of Standby (Battery) power:

Circuit Number	Battery Volume	Battery Specification
1L ~ 5L	0.69 AH	24V 1.2 AH
6L ~ 10L	0.85 AH	24V 1.2 AH
11L ~ 15L	1.01 AH	24V 1.2 AH
16L ~ 20L	1.18 AH	24V 1.2 AH
21L ~ 35L	1.67 AH	24V 1.8 AH
36L ~ 45L	1.99 AH	24V 2.3 AH
46L ~ 70L	2.81 AH	24V 4 AH
71L ~ 100L	3.79 AH	24V 4 AH
101L ~ 155L	5.43 AH	24V 7 AH

2. Control Panel Wiring to Alarm Device

a. All Zone Bell and Conventional Manual Call Point, Detectors, Indicator LED Wiring.

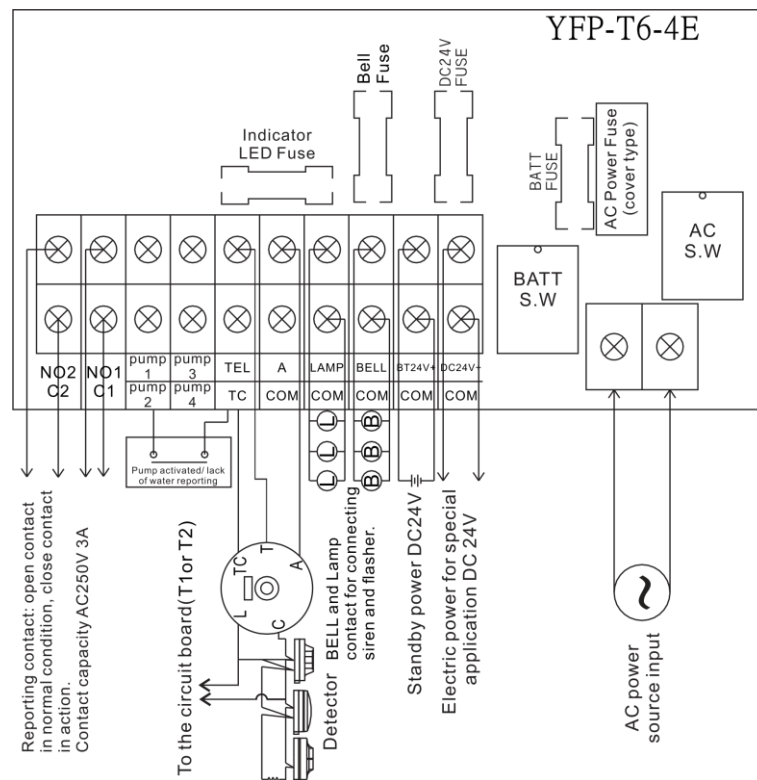
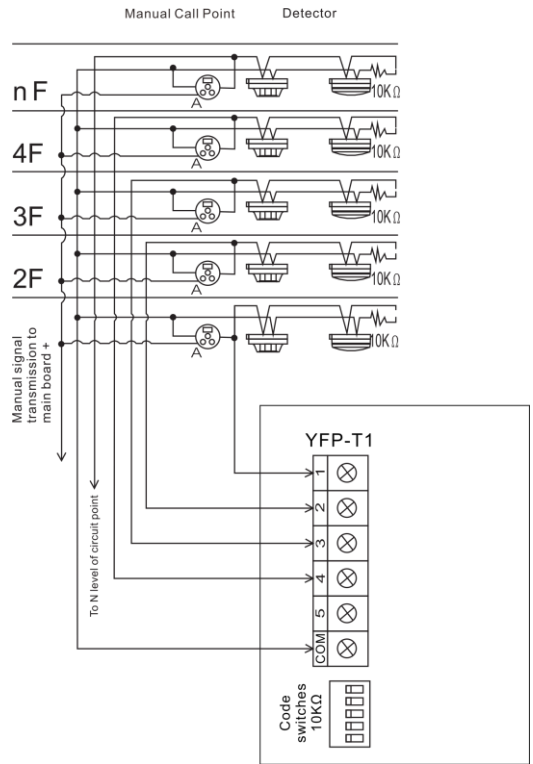

b. Segregation Bell and Conventional Manual Call Point, Detectors, Indicator LED

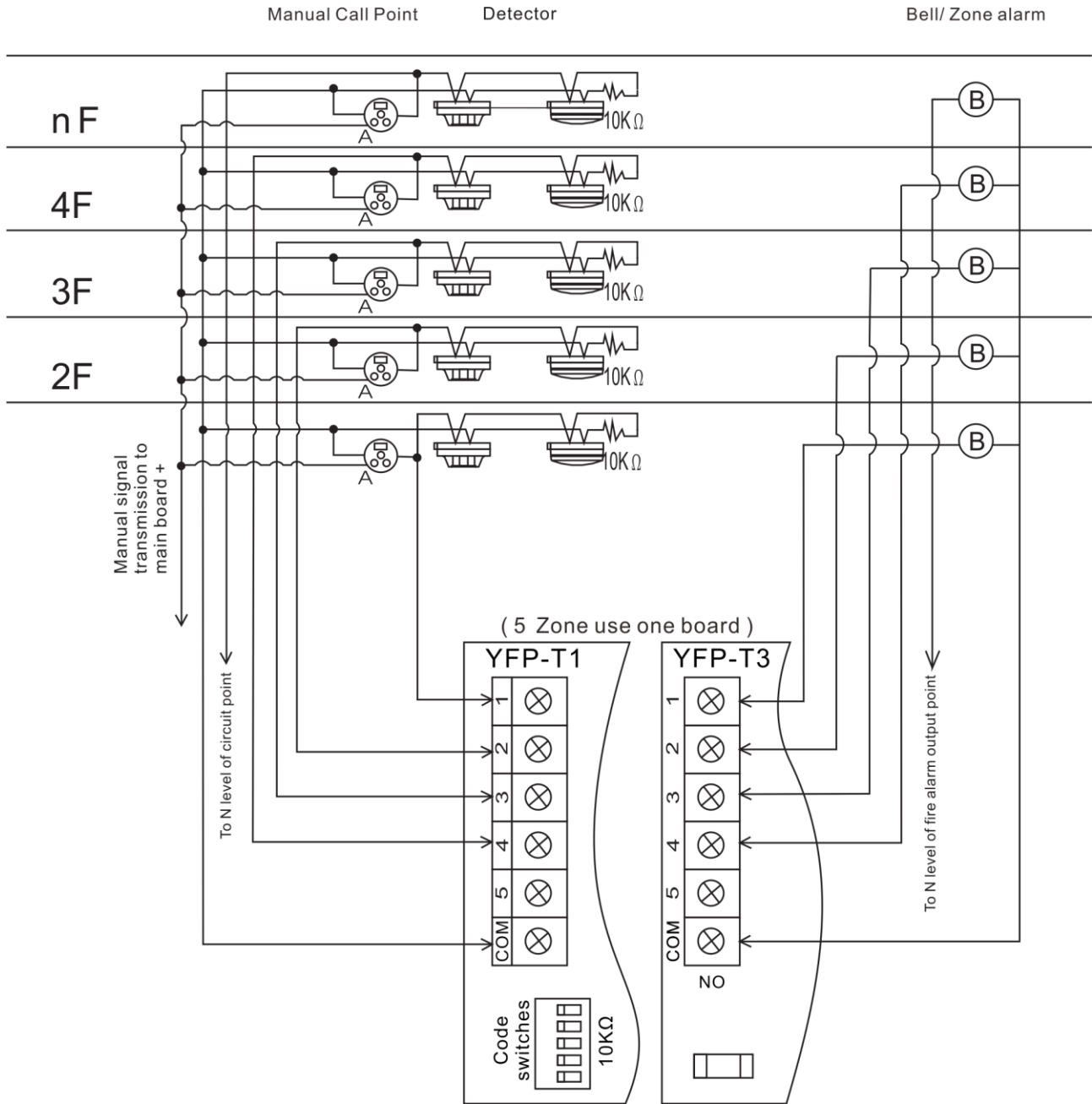

c. Note

- All zone bells don't need YFP-T3 board, and installing YFP-T3 for segregation bells.
- For all zone Bell, if each detector of zones send signal to active FACP, every bell installation to system will be ringing.
- For segregation Bell, which detector of zone send signal to active FACP that zone of bells will be ringing or setting as the country fire rules.
- End of each zone detector must wiring terminal resistors 10K Ω . If zone circuit in use the code switch must be OFF position. Similarly, circuit not in use, the code switch must be in ON position.
- The COM circuit of Fire Alarm Indicator LED or Bell and the COM circuit of zone circuit are difference, please don't connect that together.

3. Control Panel Wiring to Annunciator

- Annunciator Synchronized individual zone LED indicators display as in fire alarm control panel. Built-in tri-state LED indicators to indicate different statuses.
- Synchronized reset function. Telephone input for communicating with FACP.

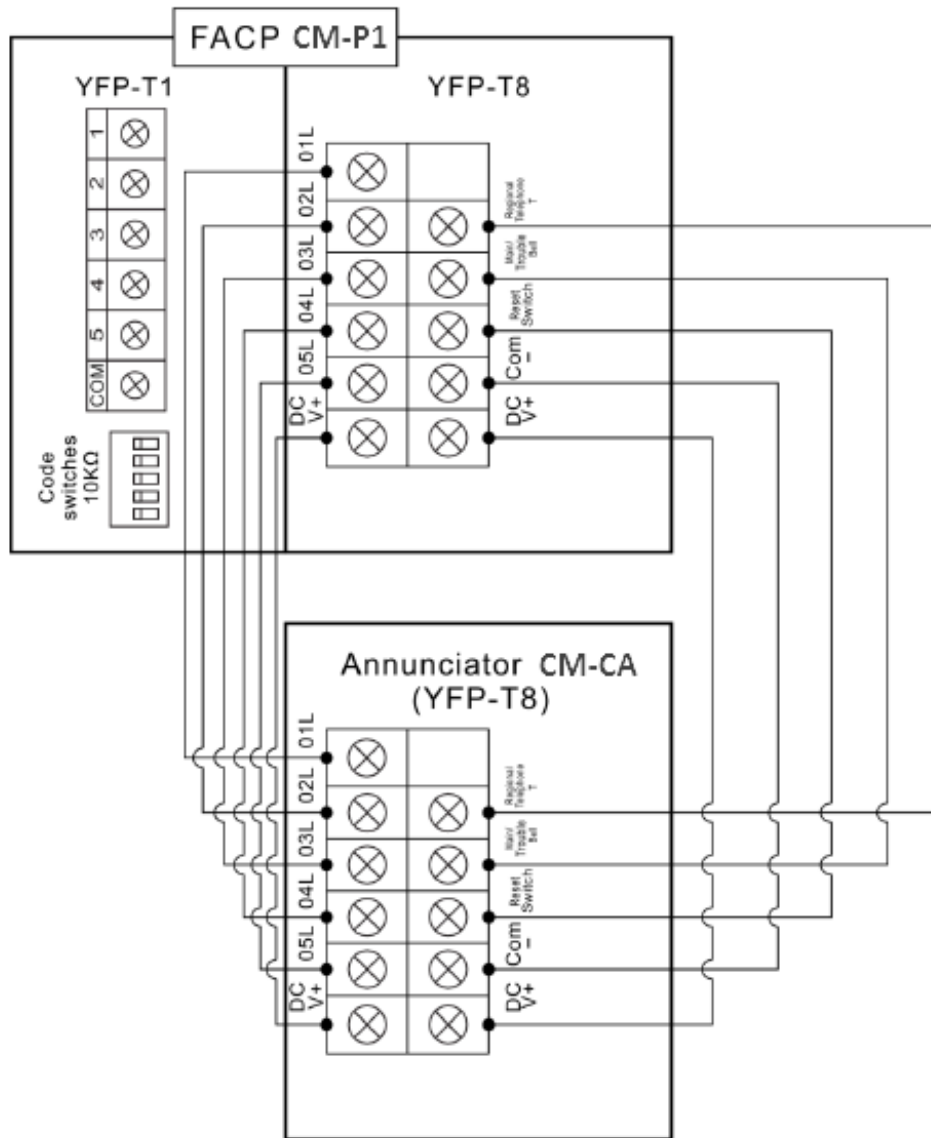

4. Control Panel Wiring to Broadcast System

a. All Zone Broadcast (CM brand)

If every detector or manual call point send signal to active FACP, the main control board YFP-T6-4E (or YFP-T6-3E) of FACP will relay the fire signal to broadcast panel alarm as every speaker (all zone).

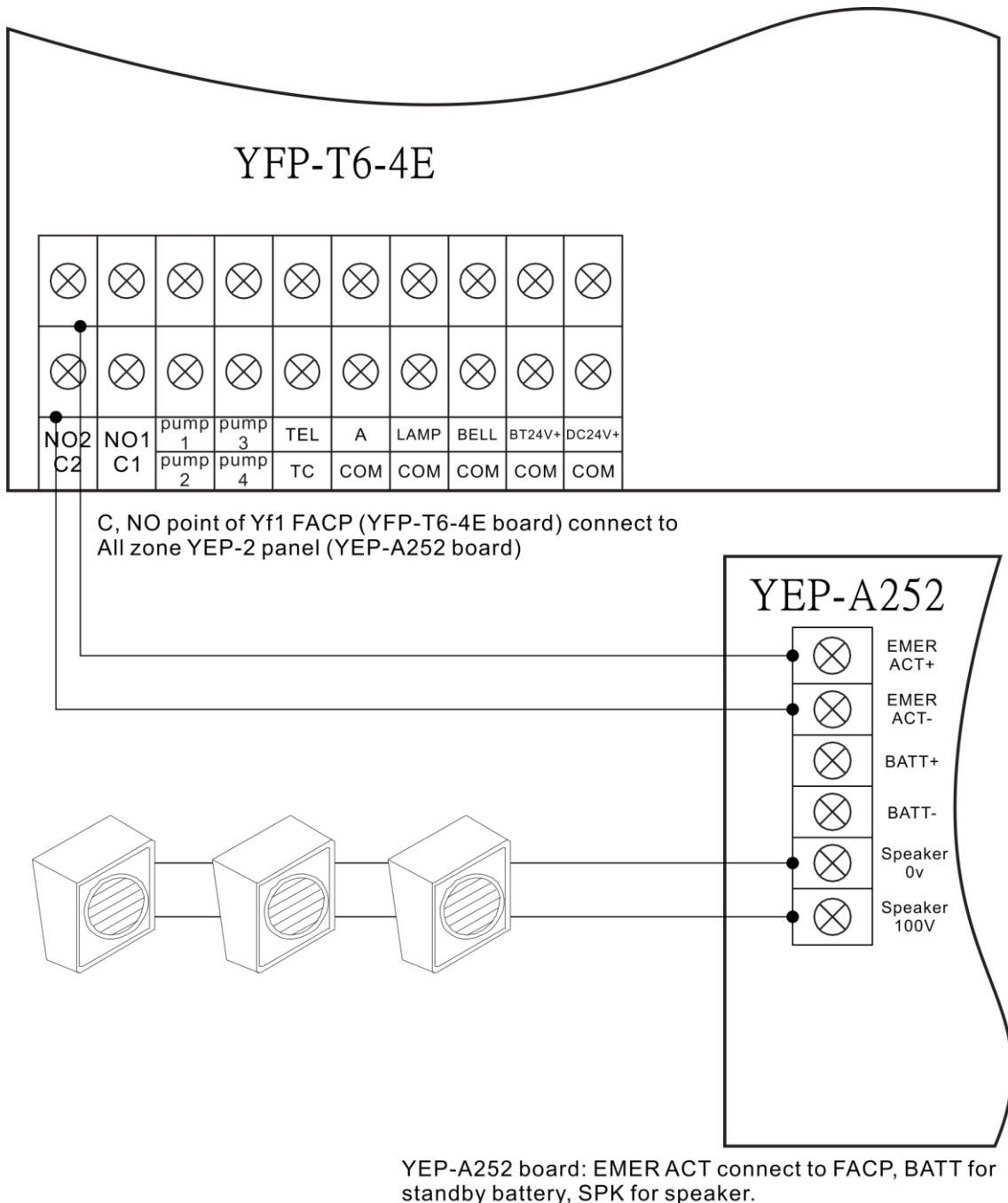

b. Individual Zone Broadcast

The YFP-T2 board of fire alarm control panel will relay fire signal from FACP to broadcast panel, which zone devices (detector or manual call point) is going alarm that zone of speaker will alarm.

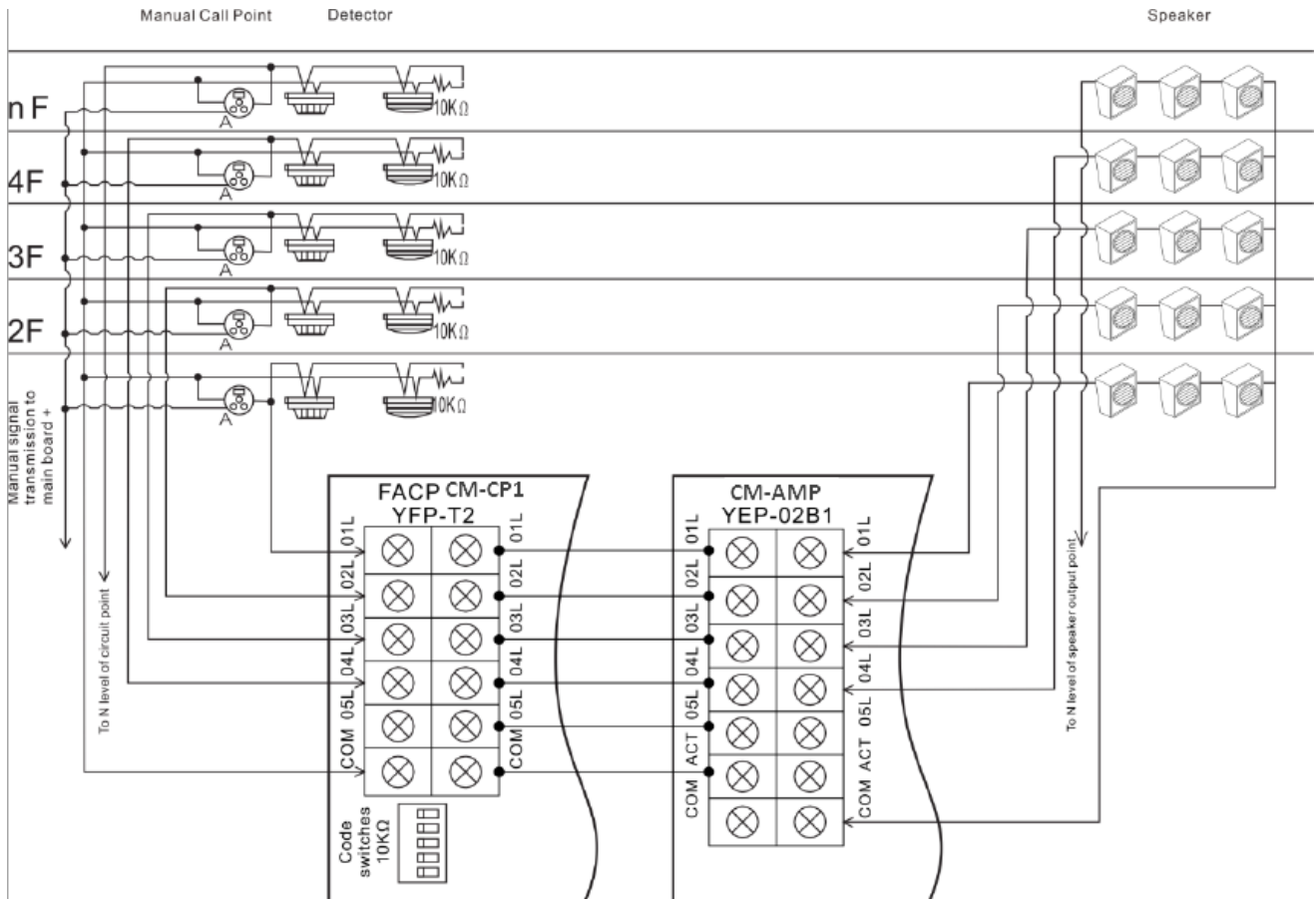

Note for Installation Circuit Board

- When connect Fire Alarm control panel with Broadcast panel, please don't wiring fire alarm system wires with broadcast system wires together, avoiding signal of system disturbingly.
- Make sure signal wires, Indicator, bell and AC power any wires not shortcut.

5. Control Panel Wiring to Smoke Evacuation System
a. Wiring Diagram of Detector and Smoke Evacuation Gate

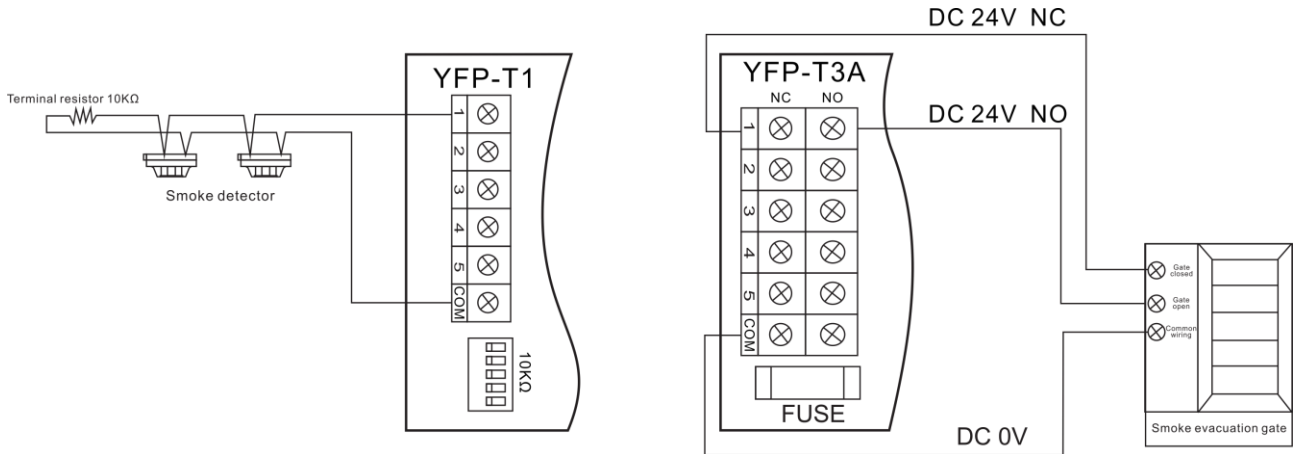

b. Wiring Diagram of Smoke Evacuation Fan

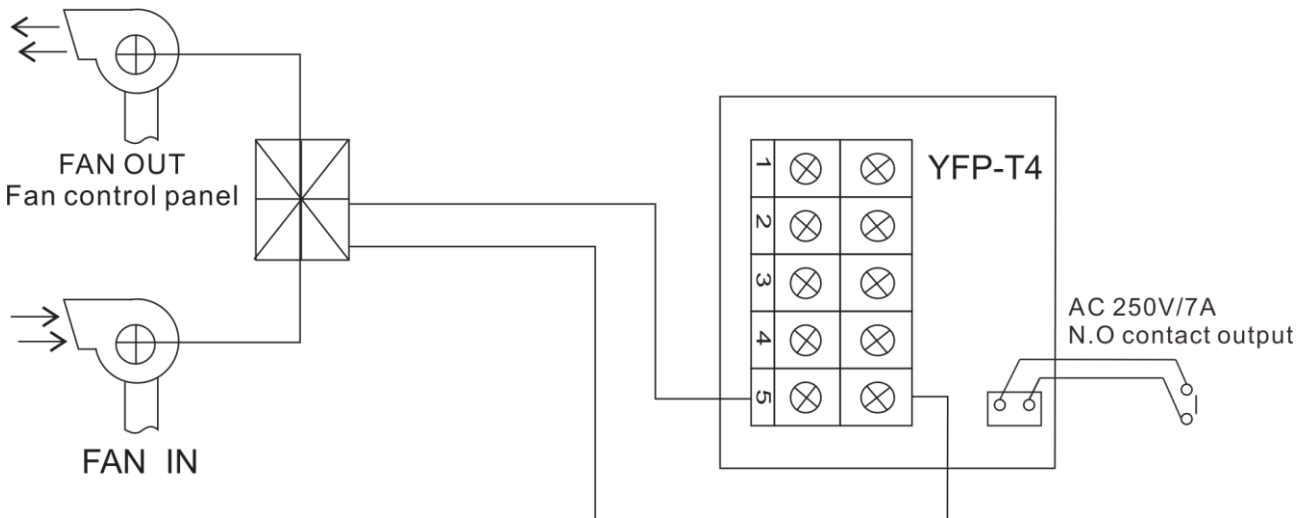

Notes for Installation

- Connection of the smoke detector: allowable number to each circuit is maximum 30 units. If over 30 units, it will cause disconnection and detection failure.
- Changing of gate control voltage requires changing method of P5 connection. Please contact the original manufacturer service.
- Fan contact point is no-voltage contact (AC250 / 7A N.O).

6. Control Panel Wiring to Sprinkling and Foam System

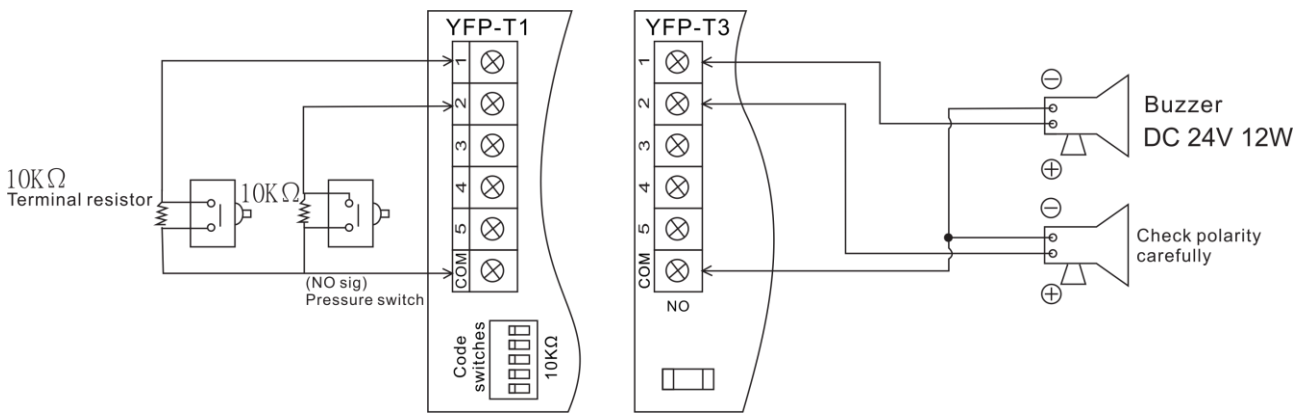

Notes of Installation

- Do not install buzzer polarity inversely.
- Capacity of fuse is calculated by the equation:
[total buzzer number (equipped with the circuit from 1 to 5) × 1.5].
- Maximum allowable capacity of each circuit is DC 24V 5A.