

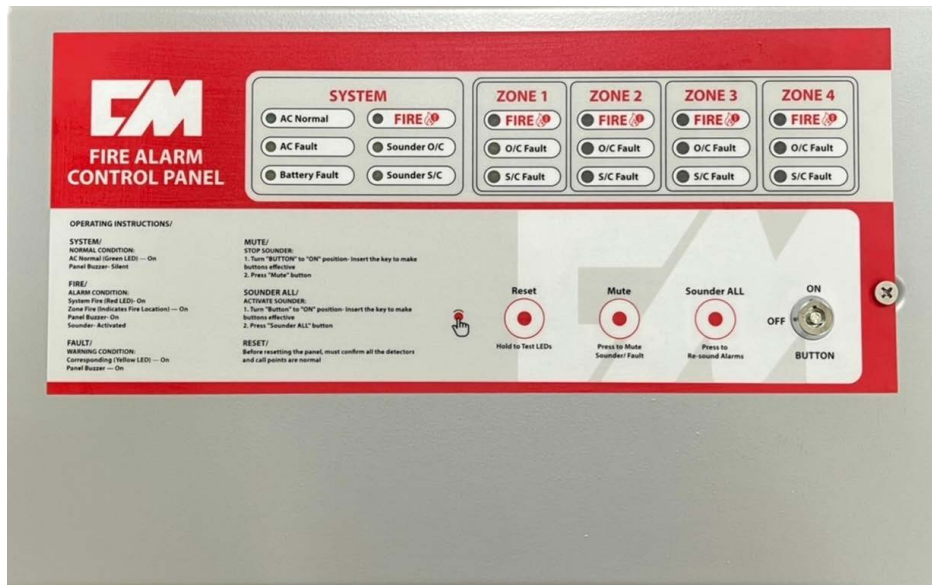

Fire Alarm System Equipment

INSTALLATION, OPERATION AND MAINTENANCE MANUAL

CM-SP(1L~4L)



FIRE ALARM CONTROL PANEL

2024.12

INSTALLATION

Remove the locking screw which holds the front panel door closed. Mount the panel as close as possible to the mains and zone cabling, and connect the supply accordingly. Connect the batteries as per the diagram below, and check to see that the panel is silent, with only the mains healthy lamp being illuminated. (the EOL devices should still be in place at this stage).

***** Should you encounter any problems at this stage, DO NOT *****

***** PROCEED, but contact your supplier for assistance *****

Any problems which the panel highlights at this stage will be due to inappropriate field wiring. **MAKE SURE IT IS CHECKED FIRST.**

Disconnect all sources of supply (including batteries) and proceed to terminate one zone to the panel. Remove the EOL device from the panel block, and fit to the last detector on the field wiring (across ve out and +ve out on the detector base). Connect the mains and batteries, and ensure the panel is silent as before. Should everything be healthy, repeat this procedure for each zone circuit until all circuits are connected.

Any problems highlighted at this stage will be due to field wiring / devices connected to each zone. Re-check all cabling and devices if necessary.

BATTERY TERMINATIONS

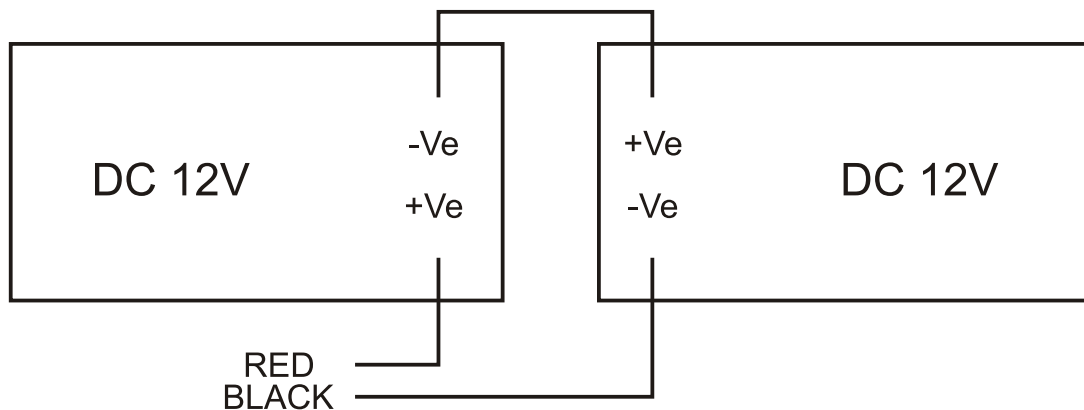

BASIC OPERATION

NORMAL OPERATING MODE

This is the default condition for the system. this mode is indicated by the green LED AC ON being illuminated while all other LED's are extinguished. In this mode, the system will monitor and react to all alarm and fault inputs. Whenever maintenance or fault finding has been completed, the system MUST be returned to this mode.

ALARM MODE

This mode is activated by the receipt of the following :

- A smoke detector is activated
- A heat detector is activated
- A manual call point is activated

The sounders will operate and the internal buzzer will sound. The common alarm LED will illuminate, and the first LED on the zone display (FIRE) will operate.

TO SILENCE ALARM

- Turn the control key to the ON position.
- Press the alarm "Mute" (this mutes the external sounders)
- To restart the sounders, press "Sounder all".
- To cancel the fire alarm condition, press RESET.

NOTE :

The system can only be reset after receiving an alarm if the mute switch has been activated.

If the panel receives a new alarm during this silence, then the sounders will start operation again.

If, after RESET the zones are still in an alarm condition then the fire LED's will not be extinguished, and the sounders will operate.

FAULT MODE

The panel buzzer will sound if any of the following occur :

- a Detector fault
- b Zone wiring fault
- c AC Normal fault
- d Battery fault or disconnected
- e Alarm output wiring fault

The fault LED that will be illuminated will depend on the fault described above.

Sounder all

The "Sounder all" switch can be used to activate the alarm in the event of an emergency. It can also be used to re-sound an alarm after the alarm has been muted .

ZONE AND DISPLAY

Each detection zone is represented by three LED's, one Red and two Amber.

RED	AMBER O/C	AMBER S/C
When red LED is illuminated, it indicates an alarm in that zone.	Indicates an open circuit fault in the field wiring of that zone.	Indicates a short circuit fault in the field wiring of that zone.

LED TEST

This is provided to check that all fire (red LED's) are functioning, and that the illuminated LED's are providing the correct information.

To activate this feature :

- Press and hold the "Reset" test button in the ON position.
- Panel will illuminate all fire LED's. The internal buzzer will sound.

ZONE CIRCUITS

Each zone is monitored for an open and short circuit fault protection. These are given by separate indications on the front panel. Monitoring is achieved with a 5K6 EOL resistor which is supplied fitted. A maximum of 20 detectors per zone is permissible (2mA max.), and any number of call points.

FIELD EQUIPMENT TERMINATIONS

■ 2 Wire / Normal Mode

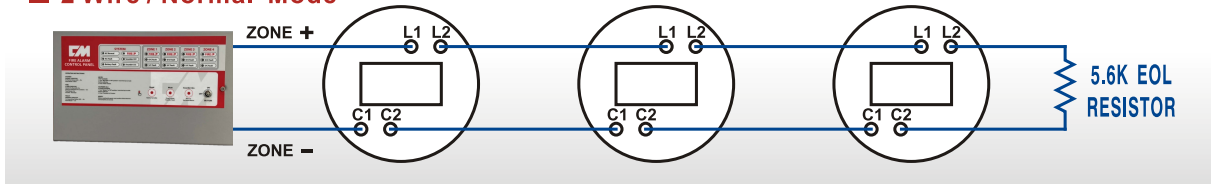

■ 3 Wire / Remote Led Indicator

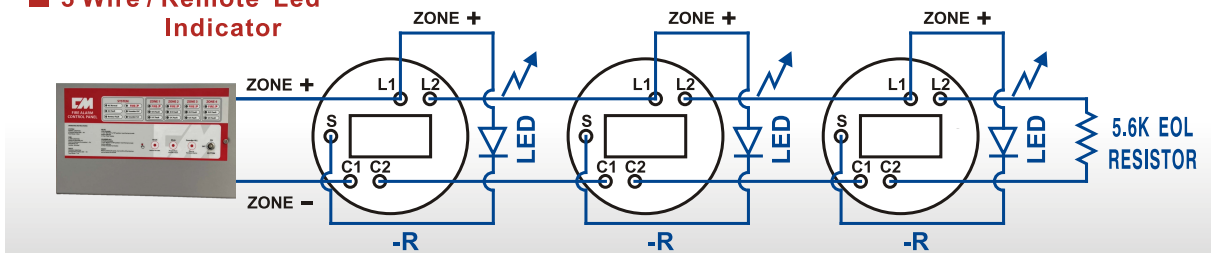

■ 4 Wire / Auxiliary Contacts

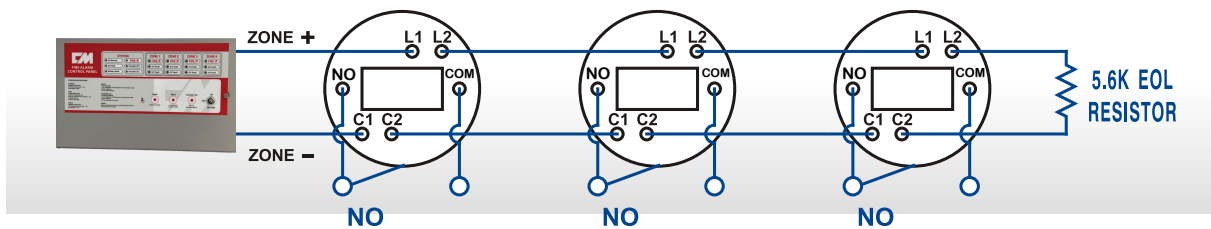

GENERAL SPECIFICATIONS

ELECTRICAL

Mains Supply	240V AC 50 / 60 Hz \pm 10%
Battery Voltage	24V DC
Charging Voltage Protection	Glass Fuse
Sounder Output	24V Nominal EOL 10K resistor
Auxiliary contacts	30VDC 1A max. NC/NO
Mains Supply Protection	Glass Fuse
Sounder Protection	Glass Fuse
Reverse Battery protection	Charger Glass Fuse
Zone EOL	5.6K Resistor

FUSE SPECIFICATION

Zone 1 To Zone 4 CONTROL PANEL	Mains Fuse	1.0A (5X20mm)
	Battery Fuse	1.5A (5X20mm)
	Sounder1 Fuse	0.5A (5X20mm)
	Sounder2 Fuse	0.5A (5X20mm)
	Charging Voltage Fuse	1.5A (5X20mm)
Zone 5 To Zone 8 CONTROL PANEL	Mains Fuse	1.0A (5X20mm)
	Battery Fuse	2.0A (5X20mm)
	Sounder1 Fuse	1.0A (5X20mm)
	Sounder2 Fuse	1.0A (5X20mm)
	Charging Voltage Fuse	2.0A (5X20mm)
Zone 9 To Zone 12 CONTROL PANEL	Mains Fuse	1.0A (5X20mm)
	Battery Fuse	3.0A (5X20mm)
	Sounder1 Fuse	1.5A (5X20mm)
	Sounder2 Fuse	1.5A (5X20mm)
	Charging Voltage Fuse	3.0A (5X20mm)
Zone 13 To Zone 16 CONTROL PANEL	Mains Fuse	1.5A (5X20mm)
	Battery Fuse	3.0A (5X20mm)
	Sounder1 Fuse	1.5A (5X20mm)
	Sounder2 Fuse	1.5A (5X20mm)
	Charging Voltage Fuse	3.0A (5X20mm)
Zone 17 To Zone 20 CONTROL PANEL	Mains Fuse	1.5A (5X20mm)
	Battery Fuse	4.0A (5X20mm)
	Sounder1 Fuse	2.0A (5X20mm)
	Sounder2 Fuse	2.0A (5X20mm)
	Charging Voltage Fuse	4.0A (5X20mm)
Zone 21 To Zone 36 CONTROL PANEL	Mains Fuse	1.5A (5X20mm)
	Battery Fuse	5.0A (5X20mm)
	Sounder1 Fuse	3.0A (5X20mm)
	Sounder2 Fuse	3.0A (5X20mm)
	Charging Voltage Fuse	5.0A (5X20mm)

SOUNDER CIRCUITS

Two sounder circuits are provided, each being fuse protected (500mA) and monitored for open and short circuit fault condition via a 10K end of line resistor, supplied fitted. The sounder outputs are effected by any zone alarm or the "Sounder all" button on the panel front. Sounder silencing is achieved by pressing the "Mute" button. The maximum loading on any sounder circuit must not exceed 500mA.

BATTERY STANDBY

PANEL	SUPPLY SIZE	FOR GUIDANCE ONLY. Min. Battery required for standby times. All alarm times are 1/2 hour.			
		CONDITIONS		24 + 1/2	48 + 1/2
		Alm Load	Det. Load		
Premier 1	1.2A	0.3A	1mA/zone	1.2Ah	2.3Ah
Premier 2	1.2A	0.3A	1mA/zone	1.2Ah	2.3Ah
Premier 4	1.2A	0.3A	1mA/zone	1.3Ah	2.4Ah
Premier 6	2.1A	0.4A	1mA/zone	1.9Ah	2.6Ah
Premier 8	2.1A	0.4A	1mA/zone	1.9Ah	2.6Ah

WARNINGS

The battery set needs to be replaced at intervals not exceeding 5 years, depending on their usage and general condition. If in doubt, replace after 4 years in service.

Upon fitting a new set of batteries, the system must be allowed to charge the batteries for at least 100 hours before they can be considered to be fully charged and therefore capable of supplying adequate back-up in the event of mains failure. However, the system will still be operational during this period, but not necessarily able to meet the regulatory specifications.

When fitting the battery set to the inside of the panel, they should be secured under the bracket provided to avoid any long term movement.

CONTROL PANEL TERMINATIONS

Maximum current per circuit, refer to P5

